

Perfect for commercial/residential work; compact footprint; 4 sections roll-n-fold with a 3rd section that can articulate up to 240°, 5 inch line, 170 cubic metres per hour.



**PUMP SPECIFICATIONS**

Maximum output {fully variable}	224 cu yds/hr {171m <sup>3</sup> /hr.}
Concrete cylinder {hard chromed}	9" x 83" {230 mm x 2100 mm}
Strokes per minute	30
Concrete pressure {rod side}	1043 PSI {72 Bar}
Concrete pressure {head side}	1600 PSI {114 Bar}
Hopper capacity	21 cu/ft {600 liters}
S-Tube	9" x 7" {220 mm x 180 mm}
Hydraulic pump	Rexroth A11LO260
Cycling system	All hydraulic sensing w\ manual overrides
Max. aggregate size	2 1/2" {65 mm}

**BOOM SPECIFICATIONS**

4 section roll & fold {vert. reach}	124' 7" {38 M}
Maximum horizontal reach	112' 2" {34.2 M}
Reach from front of truck	103' 8" {31.6 M}
Unfolding height	28' 7" {8.7 M}
Rotation	370 degree
Section articulation	95 / 187 / 250 / 245
Proportional Boom	Yes
Delivery line	5" {125 mm}
1st Section	30'2" {9.2 M}
2nd Section	26'11" {8.2 M}
3rd Section	27'3" {8.3 M}
4th Section	28'8" {8.8 M}

**OUTRIGGER SPECIFICATIONS**

All hydraulic	Yes
Front spread	20' 8" {6.3 M} L to R
Rear spread	24' {7.5 M} L to R
Max Outrigger weight	21,800 Kg {48,060 Lbs}

**STANDARD FEATURES**

- One cable remote control and one radio remote control
- Flushing water system with 132 gallon {500 L} tank
- Hopper vibrator
- Automatic lubrication system {hopper only}
- Tool Box includes basic repair items
- Whip hose of your choice

**WORKING DIAGRAM**

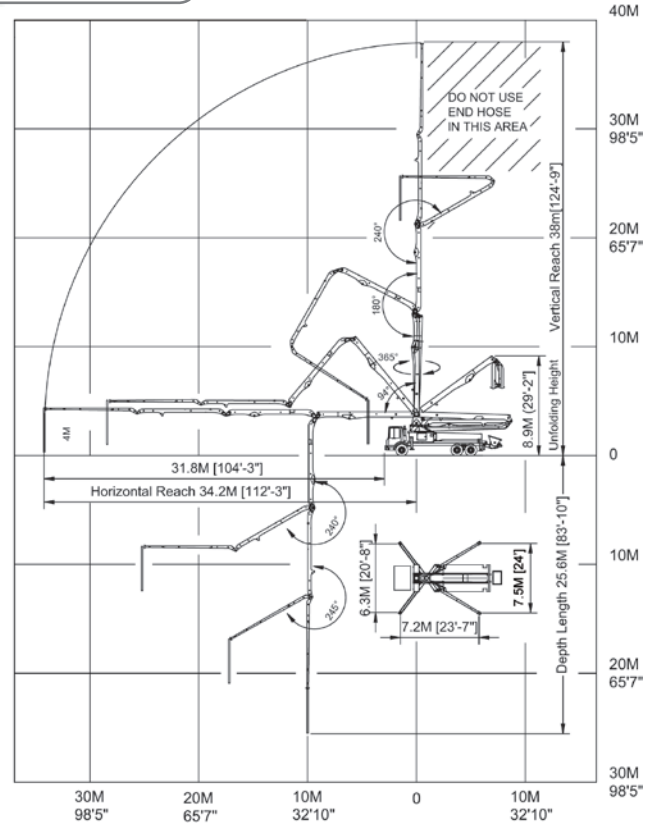

**WEIGHT DIAGRAMS**

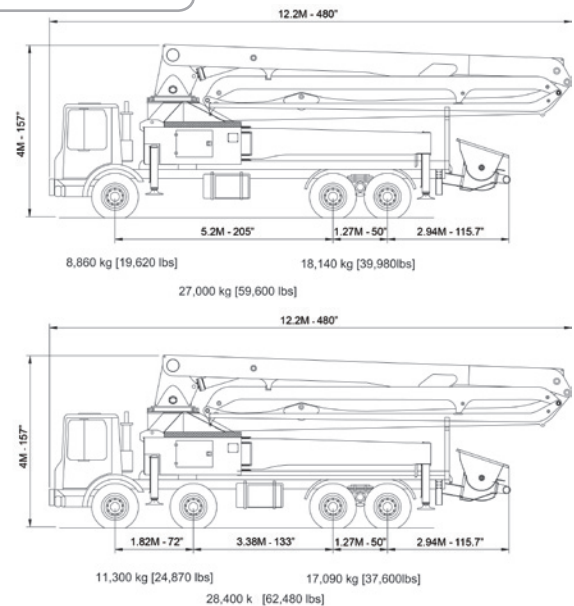

Concord reserves the right to make changes to these specifications